

TWN4 MultiTech 2

Multi-frequency RFID reader (LF/HF) with NFC and BLE support



TWN4 MultiTech 2
(exemplary illustration)

The TWN4 MultiTech 2 family of contactless RFID readers and modules allows users to read and write to almost any LF and HF tags and labels. All products support NFC and, optionally, Bluetooth Low Energy (BLE). In addition, they are also compatible with the two most commonly used smartphone operating systems, Android and iOS, which gives the option to integrate them in mobile identification applications. The desktop readers are available as Plug & Play devices that can be easily customized (i.e. inlay design), whereas the PCB modules offer a large amount of interfaces and a perfect form factor for an easy and quick integration in any host device. This broad range of product features makes the TWN4 MultiTech 2 family an excellent solution for almost every project.

Key features of the TWN4 MultiTech 2 desktop reader include a powerful SDK for writing apps that are executed directly on the reader, the possibility to upgrade the firmware in the field, and transparent data exchange with the RFID media. Additionally, the reader can read more than 60 RFID technologies from low (LF) and high frequency (HF) bands, including NFC. This gives the option to select as many of the technologies required instead of being forced to select just a few ones.

Special features:

- + Possibility to read more than 60 RFID technologies
- + Two RFID frequencies (125 kHz/13.56 MHz), NFC and BLE
- + Powerful SDK for writing apps which are executed directly on the reader
- + Firmware update in the field possible
- + On-board 18 kB flash storage, e.g. for storing user accessible non-volatile data
- + Supports transparent data exchange with RFID media
- + CCID and PC/SC 2.01
- + Customizable inlay design



Elevator



EV Chargers



Access



Shop POS



Fitness
Equipment



Ticket POS



PC Log-on



Document
Management



Driver ID



Vending



Parking



Gaming



Locker Locks



Time
Attendance



Industrial
PC

TECHNICAL DATA

FREQUENCIES	125 kHz (LF) / 13.56 MHz (HF) / 2.4 GHz (BLE)
ANTENNAS	Integrated
HOUSING	Material: ABS UL94-V0 Color: black or white
DIMENSIONS (L X W X H)	Approx. 88.00 x 56.00 x 18.50 mm / 3.46 x 2.20 x 0.73 inch
POWER	USB: 4.3 V - 5.5 V RS-232: requires 5 V external power supply ES1/PS2 classified power source according to IEC 62368-1, short-circuit current < 8 A
CURRENT CONSUMPTION	RF field on: 120 mA typically + 16 mA (BLE) / Sleep: 500 µA typ.
TEMPERATURE RANGE	Operating: -25 °C up to +70 °C (-13 °F up to +158 °F) Storage: -40 °C up to +75 °C (-40 °F up to +167 °F)
RELATIVE HUMIDITY	5% to 95% non-condensing
READ/WRITE DISTANCE	LF and HF: up to 100 mm / 4 inch, depending on environment and transponder BLE: up to several meters/feet
OPERATING MODES (USB)	USB keyboard emulation – USB virtual COM port – CCID / PC/SC 2.01
BLUETOOTH LOW ENERGY	BLE version 5.x
MTBF	500,000 hours
WEIGHT	Approx. 120 g / 4.23 oz (with cable)
SUPPORTED OPTIONS AND TRANSPONDERS	Depending on the firmware version and installed options, ELATEC readers and modules can support a wide range of RFID technologies. Please refer to the relevant ELATEC transponder matrix (available at www.elatec-rfid.com/int/transponder-technology) for more information about the available options and RFID technologies supported by the product.
OS SUPPORT	Windows 7 (32-/64-bit) and higher versions, Linux, Android ¹⁾ , iOS ¹⁾ , MAC OS X ¹⁾
PERIPHERAL INTERFACES	USB, RS-232, 1 free SAM slot ²⁾ for ID-000 card format
TRANSMISSION SPEED	Host: USB full speed (12 Mbit/s), RS-232: up to 115,200 baud, HF Air: up to 848 kbit/s
CERTIFICATION NAME	TWN4 MultiTech 2
CERTIFICATIONS	Non-exhaustive list ³⁾ : CE/RED, FCC, IC, UL listed, TAA compliant, REACH and RoHS-III compliant

¹⁾On request

²⁾The reader has one free SAM slot only, as one SAM slot is equipped ex-works with a BLE SAM card. It is strictly prohibited to take the BLE SAM card out of the SAM slot.

³⁾The product has been certified for use in many countries and regions. Contact your Sales representative for detailed information about all certifications and approvals granted to the product.

ORDER CODES	T4BT-FB2BEL7-XB	Standard reader, USB-A cable, black housing	
	T4BT-FB2WEL7-XB	Standard reader, USB-A cable, white housing	
	T4BT-FC2BEL7-XB	Standard reader, USB-C cable, black housing	
	T4BT-FC2WEL7-XB	Standard reader, USB-C cable, white housing	
	T4BT-FR2BEL7-XB	Standard reader, RS-232 cable, black housing	
	T4BT-FR2WEL7-XB	Standard reader, RS-232 cable, white housing	
	T4BT-FB2BEL7-XBP	Reader with P option, USB-A cable, black housing	
	T4BT-FB2WEL7-XBP	Reader with P option, USB-A cable, white housing	
	T4BT-FC2BEL7-XBP	Reader with P option, USB-C cable, black housing	
	T4BT-FC2WEL7-XBP	Reader with P option, USB-C cable, white housing	
	T4BT-FR2BEL7-XBP	Reader with P option, RS-232 cable, black housing	
	T4BT-FR2WEL7-XBP	Reader with P option, RS-232 cable, white housing	
	T4BT-FB2BEL7-XBPI	Reader with PI options, USB-A cable, black housing	
	T4BT-FB2WEL7-XBPI	Reader with PI options, USB-A cable, white housing	
	T4BT-FC2BEL7-XBPI	Reader with PI options, USB-C cable, black housing	
	T4BT-FC2WEL7-XBPI	Reader with PI options, USB-C cable, white housing	
	T4BT-FR2BEL7-XBPI	Reader with PI options, RS-232 cable, black housing	
	T4BT-FR2WEL7-XBPI	Reader with PI options, RS-232 cable, white housing	
	<p>Readers supporting additionally Apple Access DESFire and HID Mobile Access</p>		
	T4BT-FB2BEL7-XBIMAV	Reader with I, AV and M options, USB-A cable, black housing	
T4BT-FB2BEL7-XBPIMAV	Reader with PI, AV and M options, USB-A cable, black housing		
T4BT-FC2BEL7-XBIMAV	Reader with I, AV and M options, USB-C cable, black housing		
T4BT-FC2BEL7-XBPIMAV	Reader with PI, AV and M options, USB-C cable, black housing		
<p>The order codes above describe RFID readers equipped with a two-meter-long cable. Contact ELATEC for other cable lengths.</p>			

ACCESSORIES

HOLDERS	HKSI-B	Snap-in holder, black
	HKSI-W	Snap-in holder, white
	HKBR-B	Bracket holder, black
	HKBR-W	Bracket holder, white
POWER SUPPLIES	ELATEC RFID readers and modules can be delivered with additional cables or external power supplies. Refer to the data sheet <i>Cables for ELATEC devices</i> for detailed information.	

TECHNICAL DRAWINGS

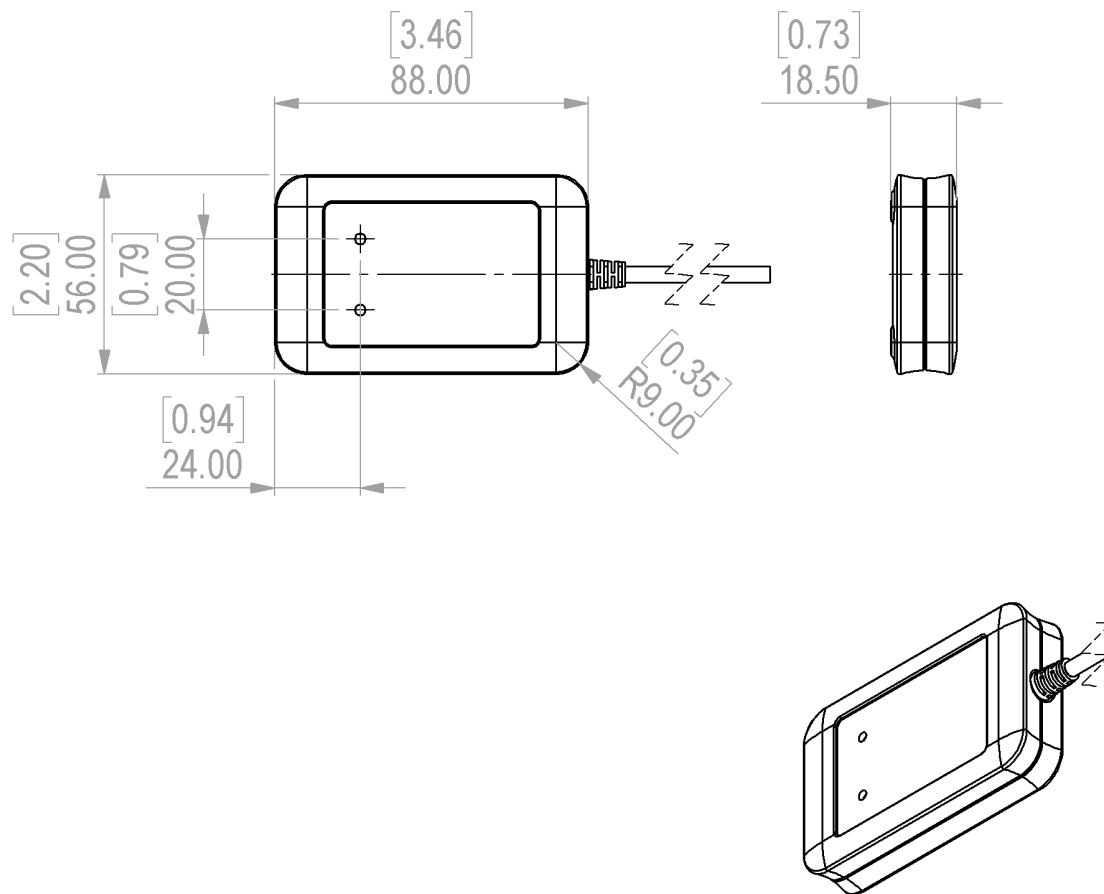

All measures in mm [inch]

HQ / EUROPE

ELATEC GmbH
 Zeppelinstraße 1
 82178 Puchheim, Germany
 P +49 89 552 9961 0
 F +49 89 552 9961 129
 info-rfid@elatec.com

AMERICAS

ELATEC Inc.
 1995 SW Martin Hwy.
 Palm City, FL 34990, USA
 P +1 772 210 2263
 F +1 772 382 3749
 americas-info@elatec.com

APAC

ELATEC Singapore
 1 Scotts Road #21-10 Shaw
 Centre, Singapore 228208
 P +65 9670 4348
 apac-info@elatec.com

MIDDLE EAST

**ELATEC Middle East
 Trading FZE**
 P.O. Box 16868, Dubai, UAE
 P +971 50 9322691
 middle-east-info@elatec.com

elatec.com

ELATEC reserves the right to change any information or data in this document without prior notice. ELATEC declines all responsibility for the use of this product with any other specification but the one mentioned above. Any additional requirement for a specific customer application has to be validated by the customer themselves at their own responsibility. Where application information is given, it is only advisory and does not form part of the specification. Disclaimer: All names used in this document are registered trademarks of their respective owners.