



**WAFERKEY**

## **User Guide**



# Contents

<u>Where to Download</u> -----	p2
<u>Login and Register</u> -----	p3
<u>Main Page</u> -----	p6
<u>Add a New Device: Lock</u> -----	p7
<u>Add a New Device: Gateway</u> -----	p10
<u>Lock Control Page</u> -----	p12
<u>User Management Page</u> -----	p13
<u>Lists of Authority</u> -----	p14
<u>Add a New User</u> -----	p15
<u>Invitation Code</u> -----	p17
<u>How to Edit a User Profile</u> -----	p18
<u>Events Page</u> -----	p19
<u>Setup Page</u> -----	p20
<u>Gateway Setup Page</u> -----	p21
<u>Sidebar</u> -----	p24
<u>Troubleshooting</u> -----	p28

(Demo screenshots were taken from iOS.)

# Where to Download

WAFERKEY is compatible with most smartphones equipped with Bluetooth 4.0 or higher and running iOS 13.6 / Android 8.1 or later versions.

(Optional) For more information about smart lock models which are built in with Bluetooth modules and support WAFERKEY, please contact with our sales team.

Supported Languages: 繁體中文、English、日本語、Français、Deutsch、Italiano、Español

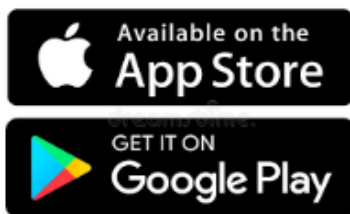

## Approach 1

Search and download “WAFERKEY” in Apple App Store or Google Play Store.



## Approach 2

Scan QRcode at left by your phone and you will be directed to the download page automatically.

- The smart device should be equipped with Bluetooth 4.0 or higher.
- Due to the different specifications of devices in use, if you use a device that is not compatible with WAFERKEY, please note that it may not operate normally.

(Demo screenshots were taken from iOS.)

# Login and Register

Log in or register from WAFERKEY account or a third-party account

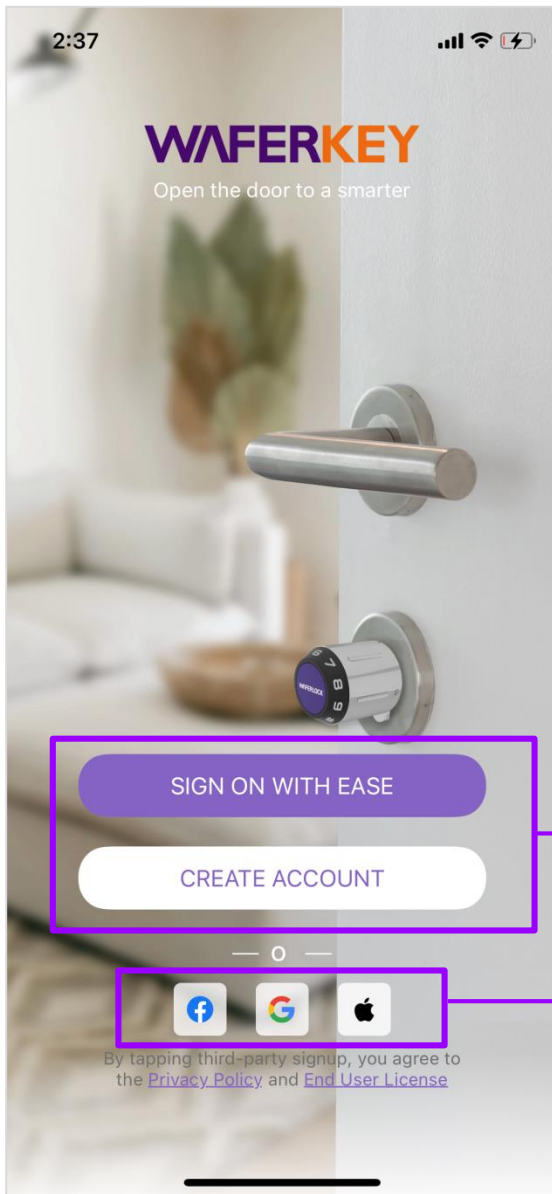

## WAFERKEY Account

Log in or register by using email/phone.

## Log in or register from a third-party account

\*Apple users can only log in from iOS system.

(Demo screenshots were taken from iOS.)

## [ How to Create a WAFERKEY Account ]

### Steps:

1. Enter Account Information (Privacy Policy and End User License have been checked.)
2. Verify
3. Enter Home Page

3:14 4G

CREATE ACCOUNT

Email Phone

Account

Email

Password

At least 6 characters

At least 6 characters long and contain upper case letter(s) or number(s)

Confirm Password

At least 6 characters

I agree to the [Privacy Policy](#) and [End User License Agreement](#).

I'd like to receive emails about news and promotions

CREATE ACCOUNT

3:15 4G

CREATE ACCOUNT

Email Phone

Account

Phone Number

I agree to the [Privacy Policy](#) and [End User License Agreement](#).

I'd like to receive emails about news and promotions

CREATE ACCOUNT

\* All columns have to be filled in for starting the next step.

(Demo screenshots were taken from iOS.)

## [ Log in from a WAFERKEY Account ]

Log in by email or mobile phone.

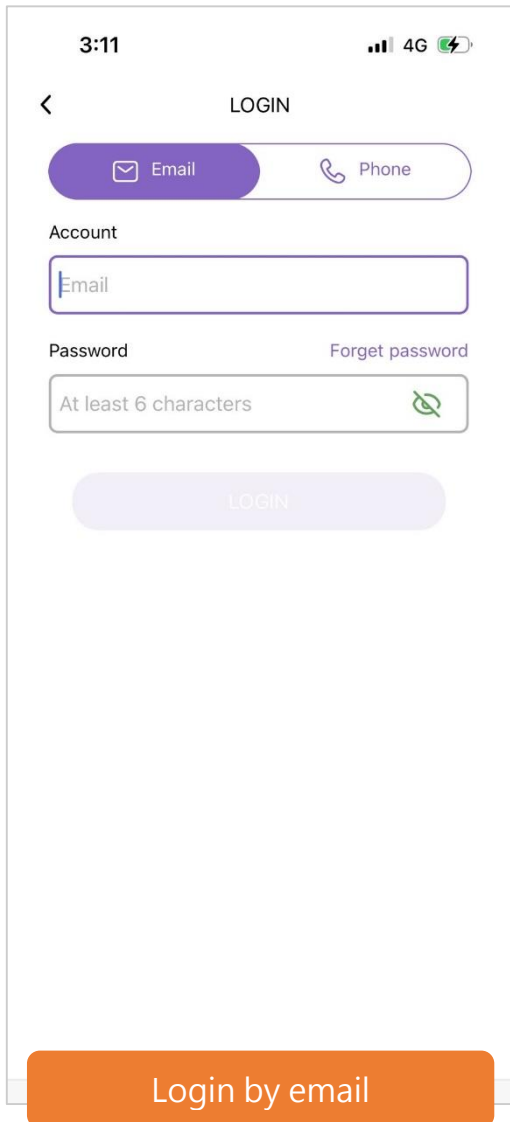

3:11 4G

LOGIN

Email Phone

Account

Email

Password Forget password

At least 6 characters

LOGIN

Login by email

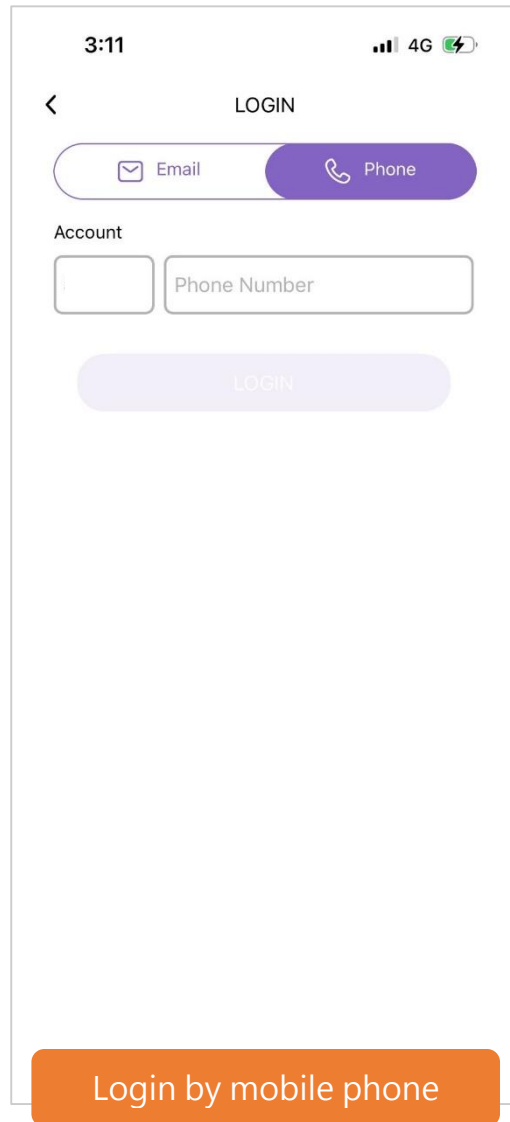

3:11 4G

LOGIN

Email Phone

Account

Phone Number

LOGIN

Login by mobile phone

(Demo screenshots were taken from iOS.)

# Main Page

Main Page contains all locks that have been paired and controlled by you, allowing you enjoy daily life with the convenience brought by digital access control.

- You can also find out the door status paired with the assigned lock (the appearance of the door status may vary based on lock models in pairs).
- Add the most frequently used lock as “Favorite” in order to activate the Control page automatically when App is on. Only one lock can be set as “Favorite”.
- Click “Profile Image” at the left corner to activate the Sidebar to manage settings about the account and App.

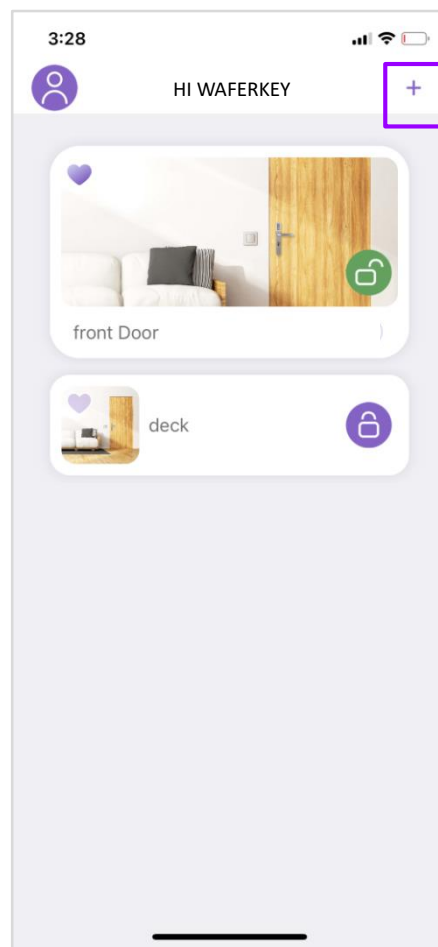
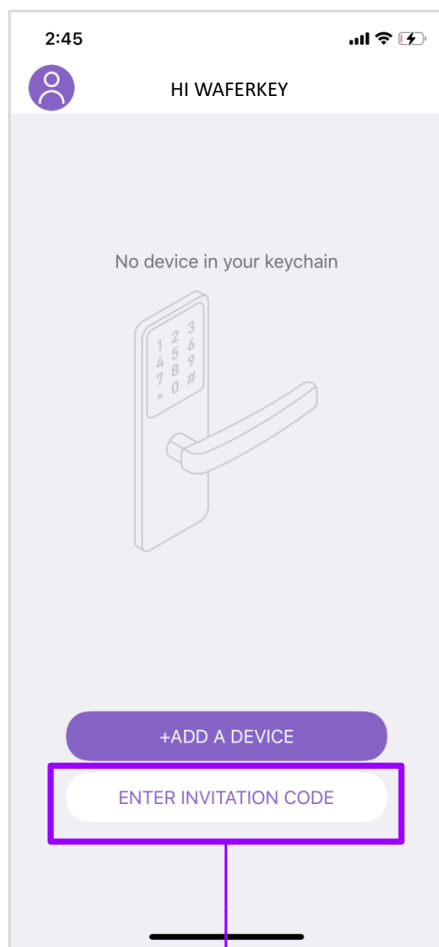

Click to add a new device

Click to bring up “Invitation Code” window and enter the received codes there

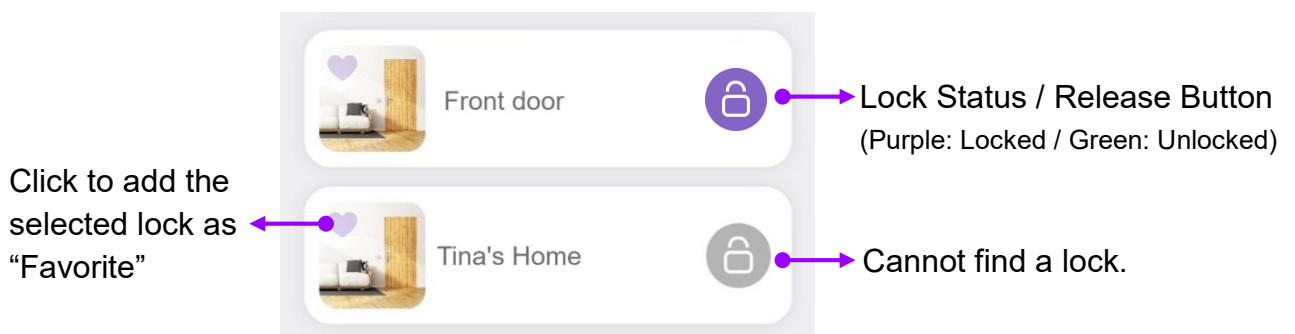

(Demo screenshots were taken from iOS.)

# Add a New Device: Lock

-- The model used for demo screenshots is C760--

## Select a Device

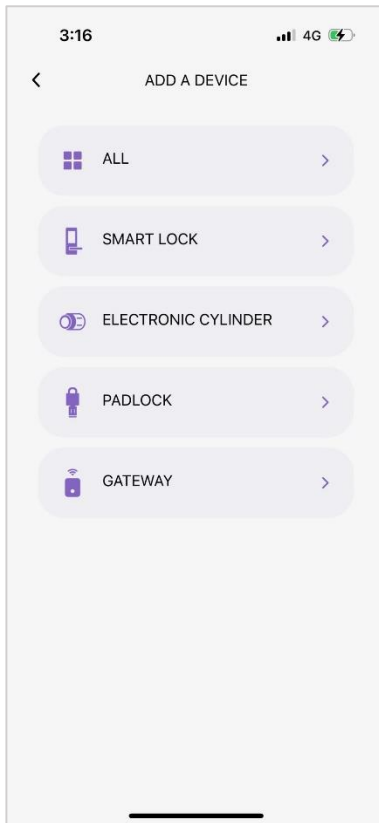

## Select a Device



## Prepare for Pairing

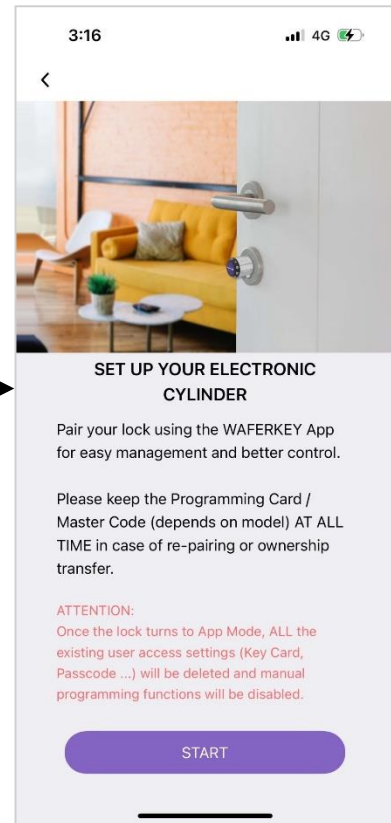

## Reminder

Once the App has been paired with the lock successfully, all authorities of former cards, passcodes, fingerprints or facial recognition (based on models in use) to use the lock will become invalid. You have to set them up again in the App.

(Demo screenshots were taken from iOS.)

### 1. Install

### 2. Enroll Programming Card

### 3. Start Pairing

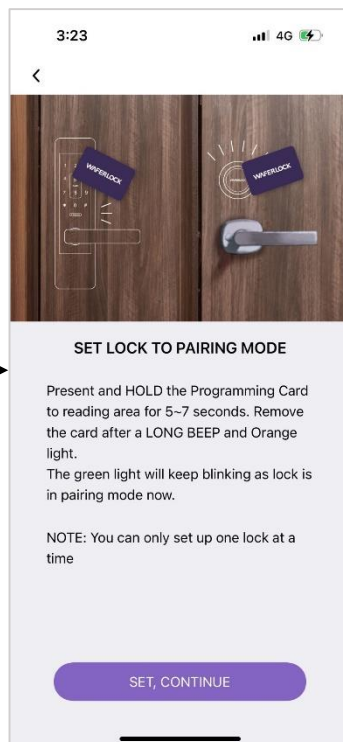
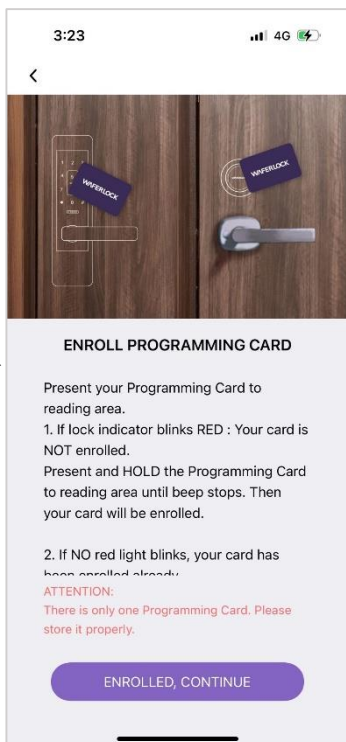
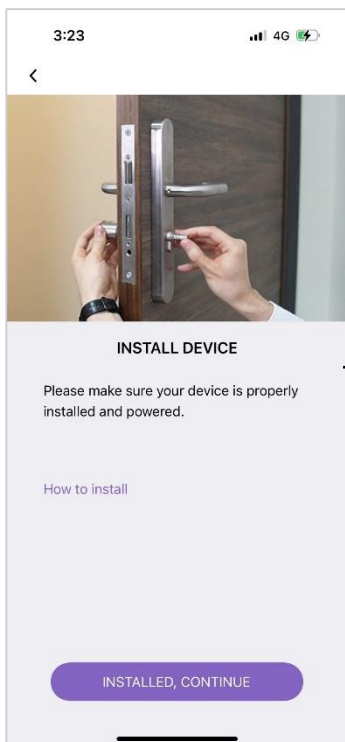

\*Bluetooth must be turned on when pairing.

\*Location Services on Android must be turned on too.

### 4. Scan to Find

### 5. Activate

### 6. Give a Name

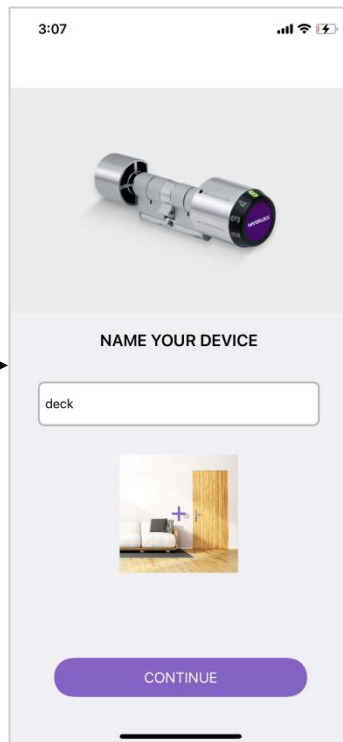
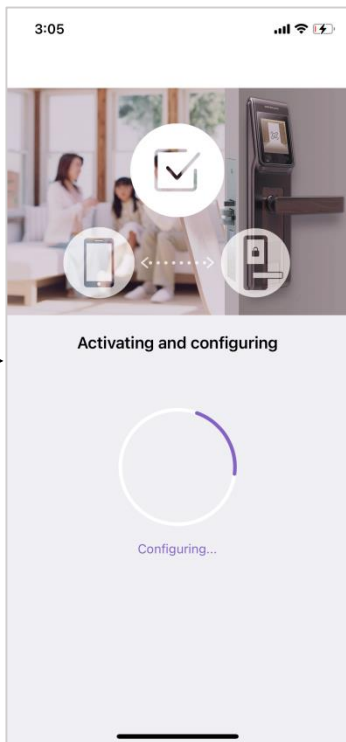
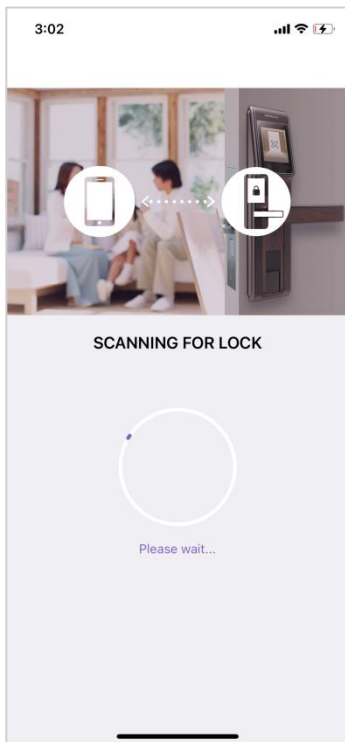

(Demo screenshots were taken from iOS.)

## Notice

1. In the Step 2 “Enroll Programming Card”, when presenting the Programming Card to the reading area, if the situations listed below happen:
  - A red light appears to flicker immediately. Please make sure you have used the correct Programming Card.
  - Two “Bi” sounds appear immediately or go to the Pairing Mode (It may vary based on the different model in use). Make sure the Programming Card has been enrolled successfully. If so, go to the next step.
2. Do not remove your card from the reading area until all procedures mentioned in the Step 2 and 3 have been done.
3. If “Cannot find any device” window pops up on the screen, please click the Cancel button, go back to the previous step and then go through all procedures carefully again.
4. If “You can only pair one lock at a time. Please try again” pops up on the screen, please make sure there is not another lock in pairing mode nearby.

# Add a New Device: Gateway

## [Wired Network Mode]

### Step 1

Select how Gateway is connected online

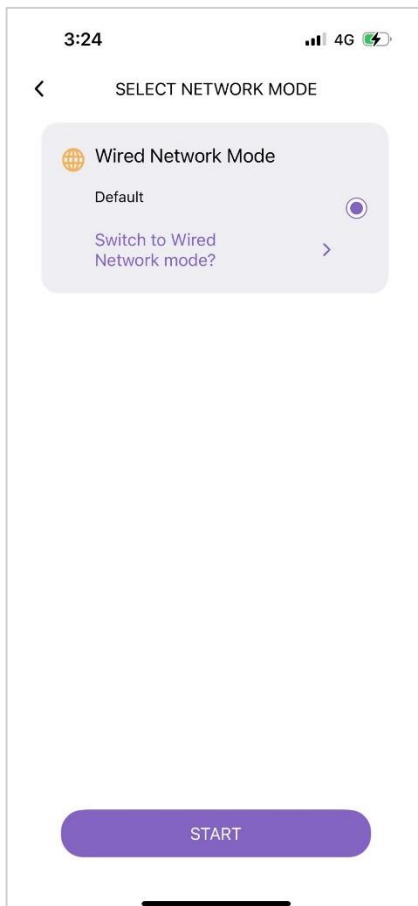

### Step 2

Make sure all preparations done.

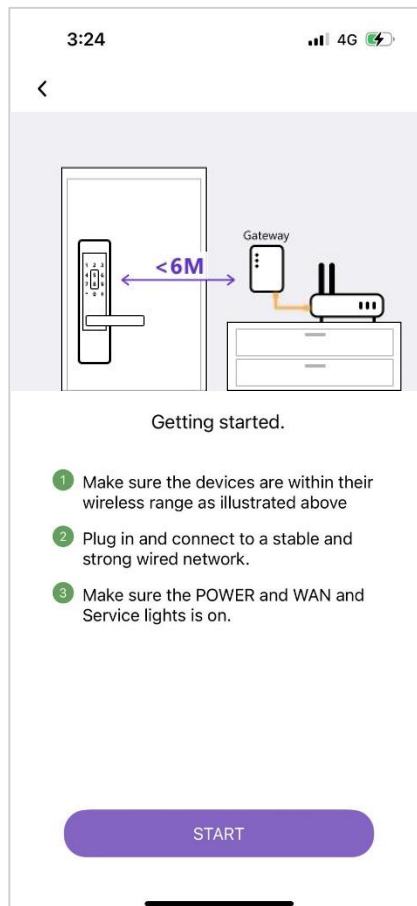

### Step 3

Select the lock to connect.



### Reminder:

1. One lock cannot be paired with two devices. Make sure it is not paired with other Gateways or eHome products in advance.
2. When pairing, make sure the Bluetooth of your phone has been turned on and the network is connected.
3. If you cannot find any device in Step 3 above, make sure a lock which can be controlled remotely has been paired with the account.

### Installation Steps of R400 Gateway:

1. R400 should be within 6m of the lock and there is no shielding obstruction between.
2. The gateway should face towards the door lock, as this is the optimal direction for signal reception.
3. R400 cannot be stored in a groove of the lightweight steel or obstructed by other metal shields.
4. Due to different materials of locks of different models, the signal reception range is slightly different.

(Demo screenshots were taken from iOS.)

## Step 4

### Scan QRcode on Gateway

\*QRcode can be found at the side of Gateway.



## Step 5

### Pair Gateway with your phone and lock

\*Please be patient until all steps are completed.

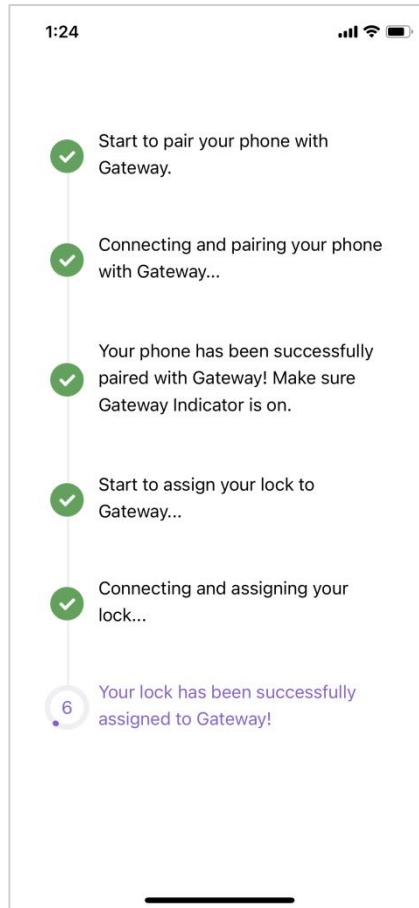

## Step 6

### Make sure all connection done and then click "FINISH THE SETTINGS" button.

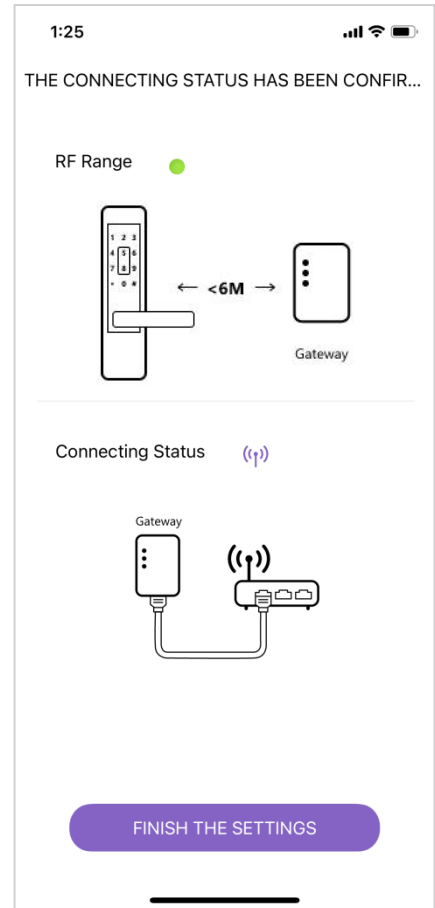

## Reminder

1. Please be patient until all steps are completed. Sudden interruption or leave may cause a failure to pair.
2. When pairing with the lock in Step 5, the lock should make a short beep. When done, the lock should make three short beeps.
3. In Step 6, make sure all connections have been done and then click "FINISH THE SETTINGS" button" to finish the setting.

When done, you will be directed to the Gateway Setup Page. Refer to ["Gateway Setup Page"](#) for knowing Gateway better. Start to enjoy the smart management of remote control, the functions of locking/unlock doors remotely and remote distribution of passwords for personnel management on the control page.

(Demo screenshots were taken from iOS.)

## Lock Control Page

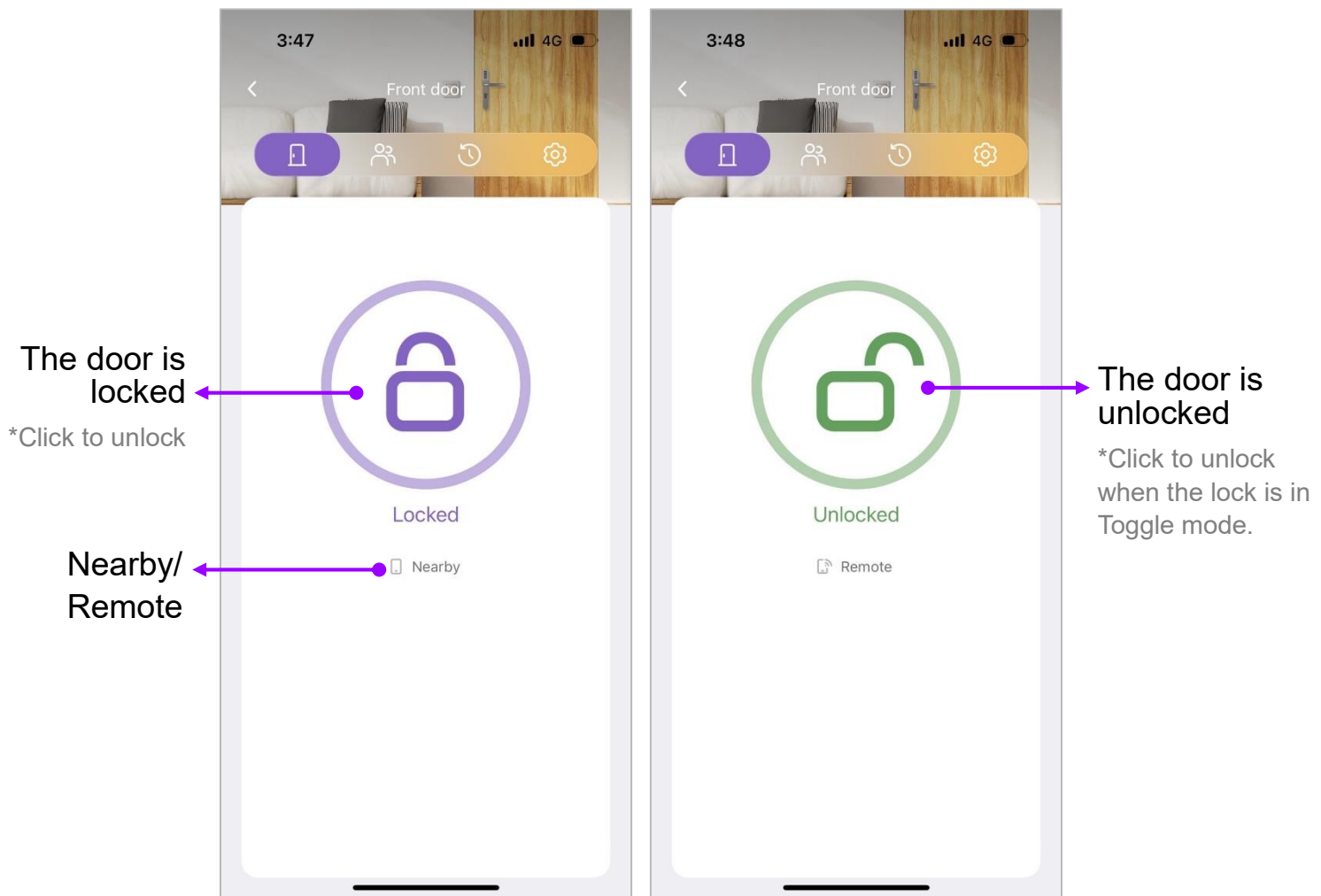

In order to meet demands of users who have to enter or exit the house frequently in a short period of time, WAFERKEY builds up the Auto-lock Override.

- **Activate the Auto-lock Override:**

In the Auto-lock Mode (the lock will be locked automatically), Click and hold on the Lock button for three seconds. You will feel a vibration and see a pop-up window with the message “The door will remain unlocked”.

- **End the Auto-lock Override:**

Click the Lock button again to return to the Auto-lock Mode.

(Demo screenshots were taken from iOS.)

# User Management Page

In the User Management Page, users can assign various authorities to different users, for example, assign the family as “Owner” or assign the cleaning crews as “Guest” and restrict a period of time for them to enter or exit the house. With WAFERKEY, it is easy and convenient to have smart access control.

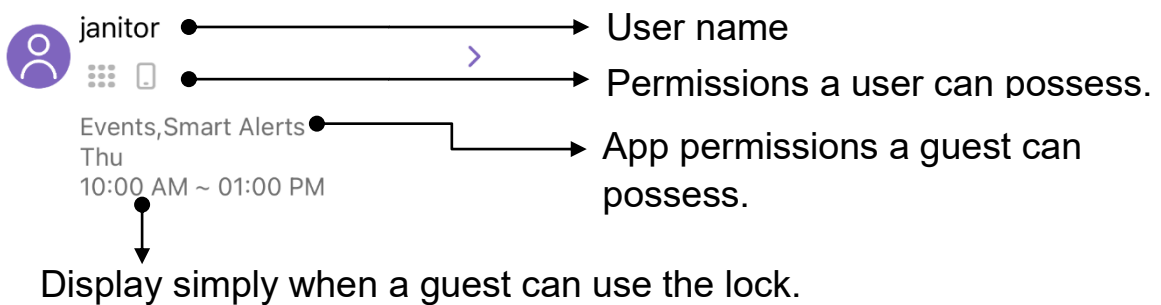
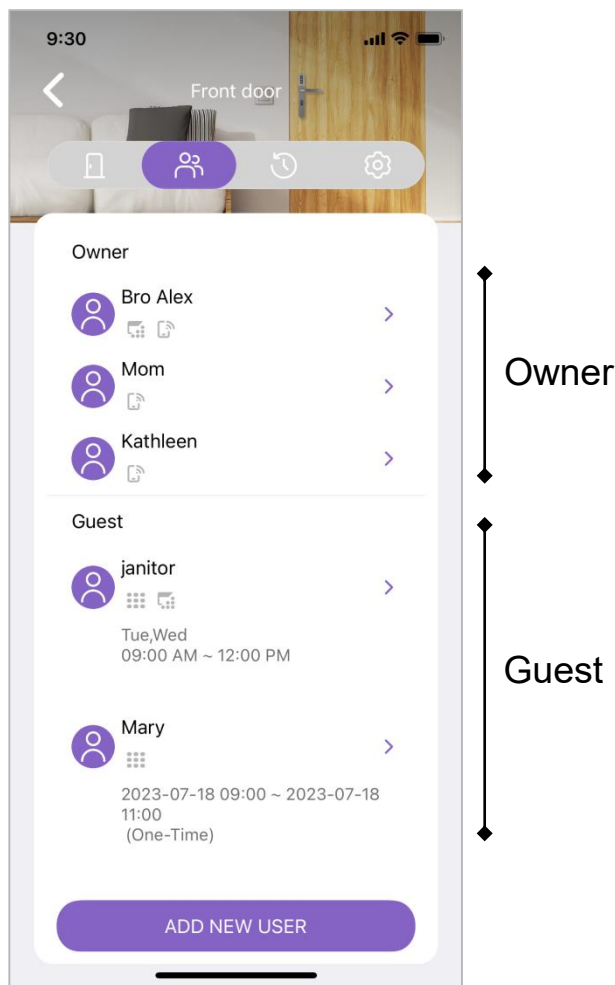

(Demo screenshots were taken from iOS.)

## [ Lists of Authority ]

Users can be classified into Owner or Guest.

An Owner can perform all functions listed in the App, including lock/unlock the door without time restriction, user management and assignment, unpair devices, delete other Owners or Guests and so on. **Please use them with caution!**

	Owner	Guest
Lock / Unlock	✓	✓
Event	✓	✓ (Additional permission required.)
Notification	✓	✓ (Additional permission required.)
Add / Delete a User	✓	✗
Delete a User	✓	✗
Delete Self	✓	✗
Modify the Setup of a Lock	✓	✗
Auto Unlock Setup (Only in iOS)	✓	✗
Battery	✓	✓
Firmware Update	✓	✗
Unpair the Lock	✓	✗

(Demo screenshots were taken from iOS.)

## 【 Add a New User 】

### How to Add a New User

Step1. Click the Add a New User button to go to “Add a New User” page.

Step2. In the Add a New User page (displayed in the screenshot on the next page),

1. Enter a user’s name in the Name column.
2. Click “Schedule” to assign how often the user can use the door.
3. Click “Entry Method” to assign a way to unlock the door:
  - a. Key Card
  - b. Passcode\*
  - c. Key Card and Passcode\*
  - d. Fingerprints\*
  - e. Faceprint\*
  - f. App access
5. Switch “Owner” on if you want to assign the user as an owner.

Step3. Click “Save & Invite” button when done.

Step4 All steps are completed.

Note: Items marked with “\*” may vary based on different lock models in use.

When done, if the App Access is selected, you can tell the user to [download the WAFERKEY App](#), open the App to find [the invitation link](#) and then click the link to complete the binding procedure.

-----

#### **Note:**

1. When adding a new user, please do not move around in order to remain a stable connection for the Bluetooth. Otherwise, unknown mistakes may happen easily.
2. For each lock, Recurring Schedule can be only granted to 32 sets of users.

(Demo screenshots were taken from iOS.)

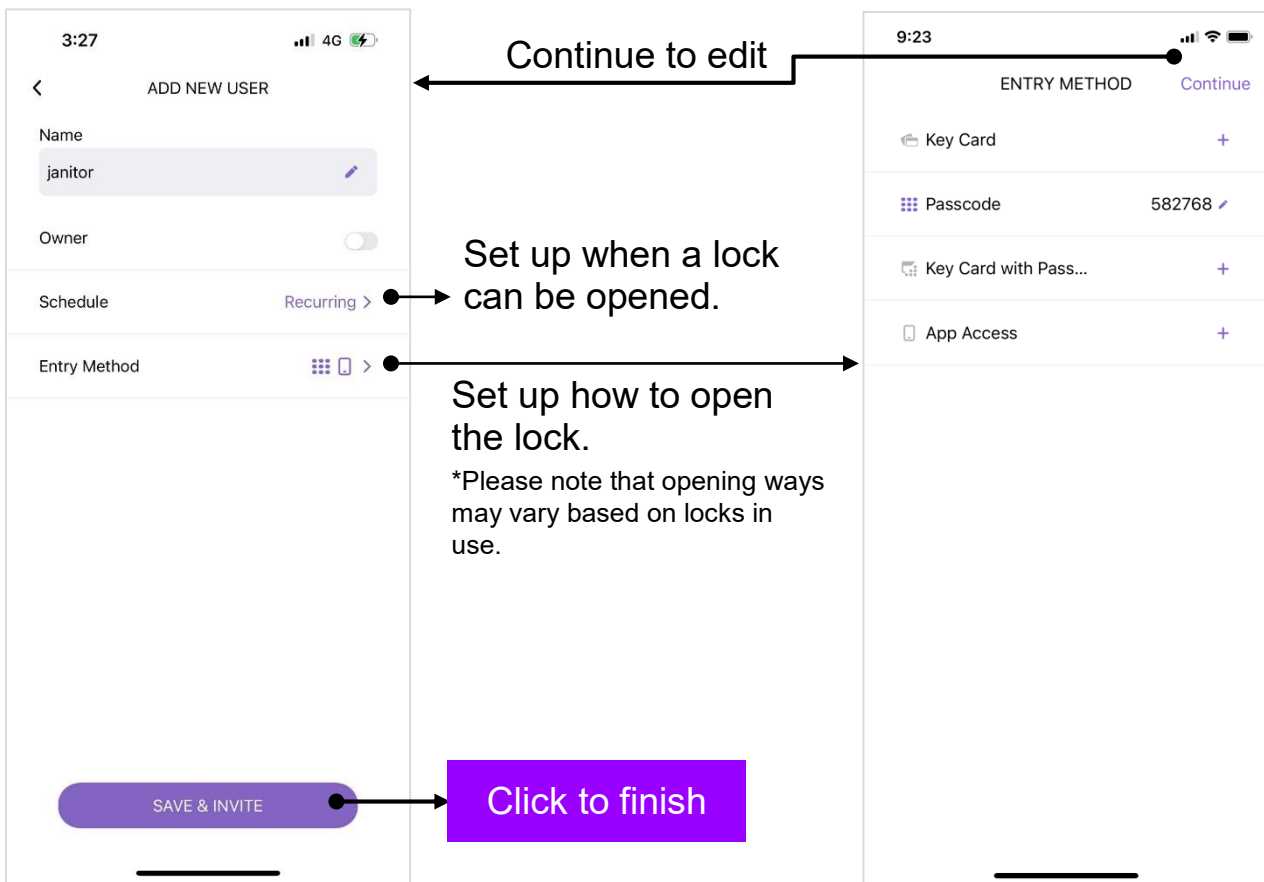

Please note that all columns on this page have been completed; otherwise, the **SAVE & INVITE** cannot be clicked. If so, the added user is not added up successfully.

### If the App Access is checked,

The Save button in the Add a New User will become “Save & Invite” button. Click it to enable lists of communication software installed inside your phone. Then, select one of them to send out the invitation code to the user.

(Demo screenshots were taken from iOS.)

## 【 Invitation Code 】

When the family, cohabitants or visitors who have to come at a certain period of time, Owner can send out an invitation code to these people. By using it, these people can unlock the assigned door.

There are two ways to activate the Invitation Code page:

1. Directly click the link received and the Invitation Code page will be activated automatically. Enter the invitation code received and then click the OK button.
2. Click the Profile Image to extend the Sidebar and then select “Enter Invitation Code”. Then, the Invitation Code page will be activated on the screen. Enter the invitation code received and then click the OK button.

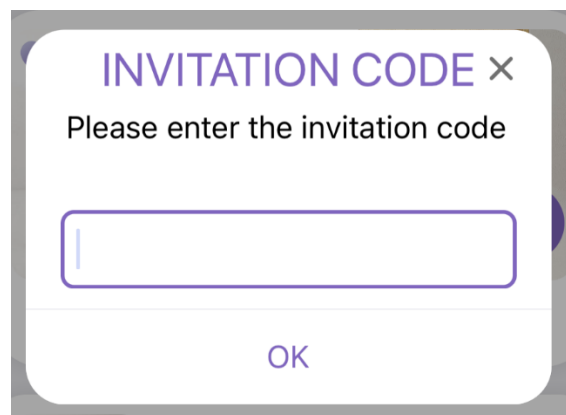

(Demo screenshots were taken from iOS.)

## 【 How to Edit a User Profile 】

Rules listed here are the same as those in the Add a New User page. Two additionally added functions are “Enable access” and “Remove Self”.

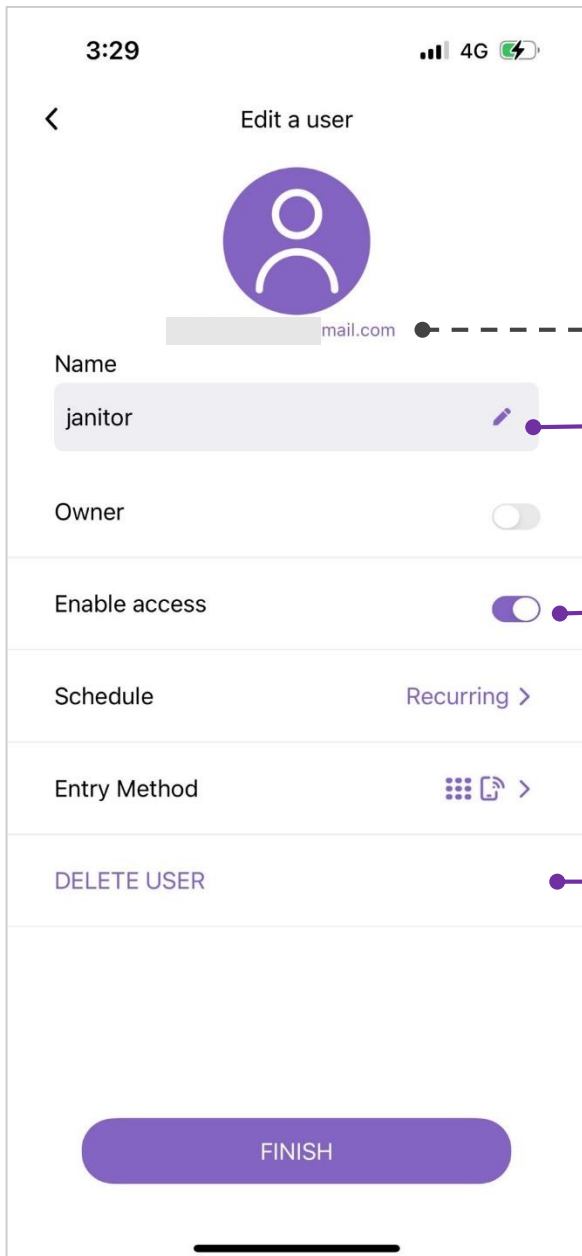

The email or cell phone number of the user who has entered the invitation code will be displayed here.

Edit a nickname

Owner can suspend an user from access temporarily. However, Owner cannot suspend an user who is classified as “Owner”.

Please use it with extra caution, for it cannot be restored once it has been deleted.

When User is someone else:

DELETE USER

When User is Owner:

REMOVE SELF

Please note all information listed above has to be completed; otherwise, it cannot be saved and sent out

(Demo screenshots were taken from iOS.)

# Events Page

In the Events page, all information, such as access controls, authority modifications and so on, are recorded in detail, thus providing comprehensive security records.



Reminder: The latest event will be displayed only when it happens close to the lock or the internet works smoothly.

**Icons of Unlocking Events**



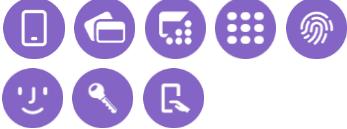



**Icons of Locking Events**

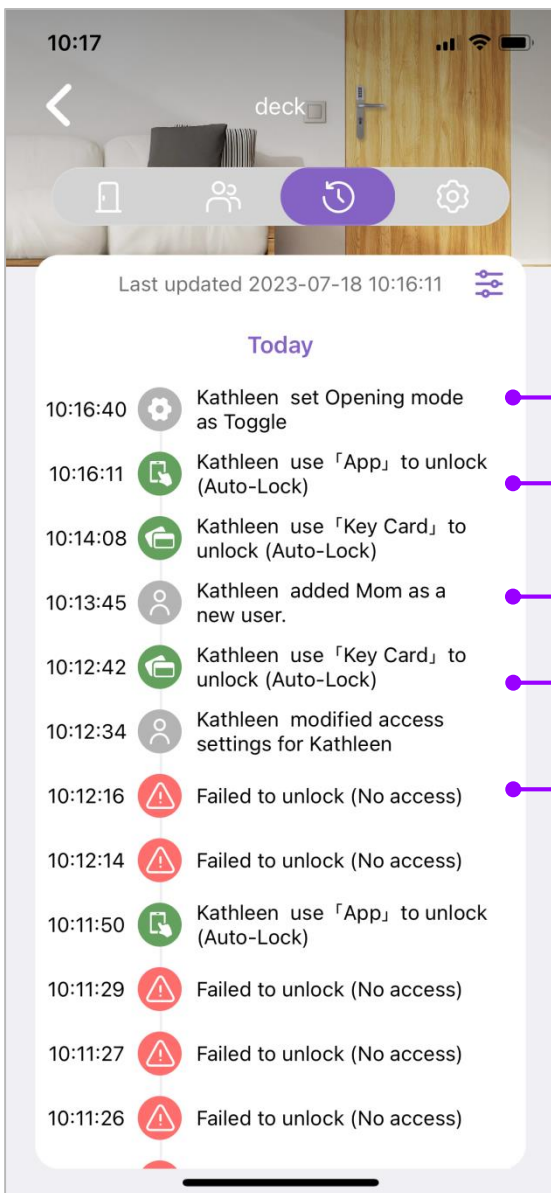

**User Management**  **Setup**  **Warning** 



-  An event of modified setup
-  An unlocking event (by App)
-  An event of user management
-  An unlocking event (by Card)
-  An illegal event

(Demo screenshots were taken from iOS.)

# Setup Page

Users can adjust various settings related to the lock in use (some features may vary depending on the lock model in use).

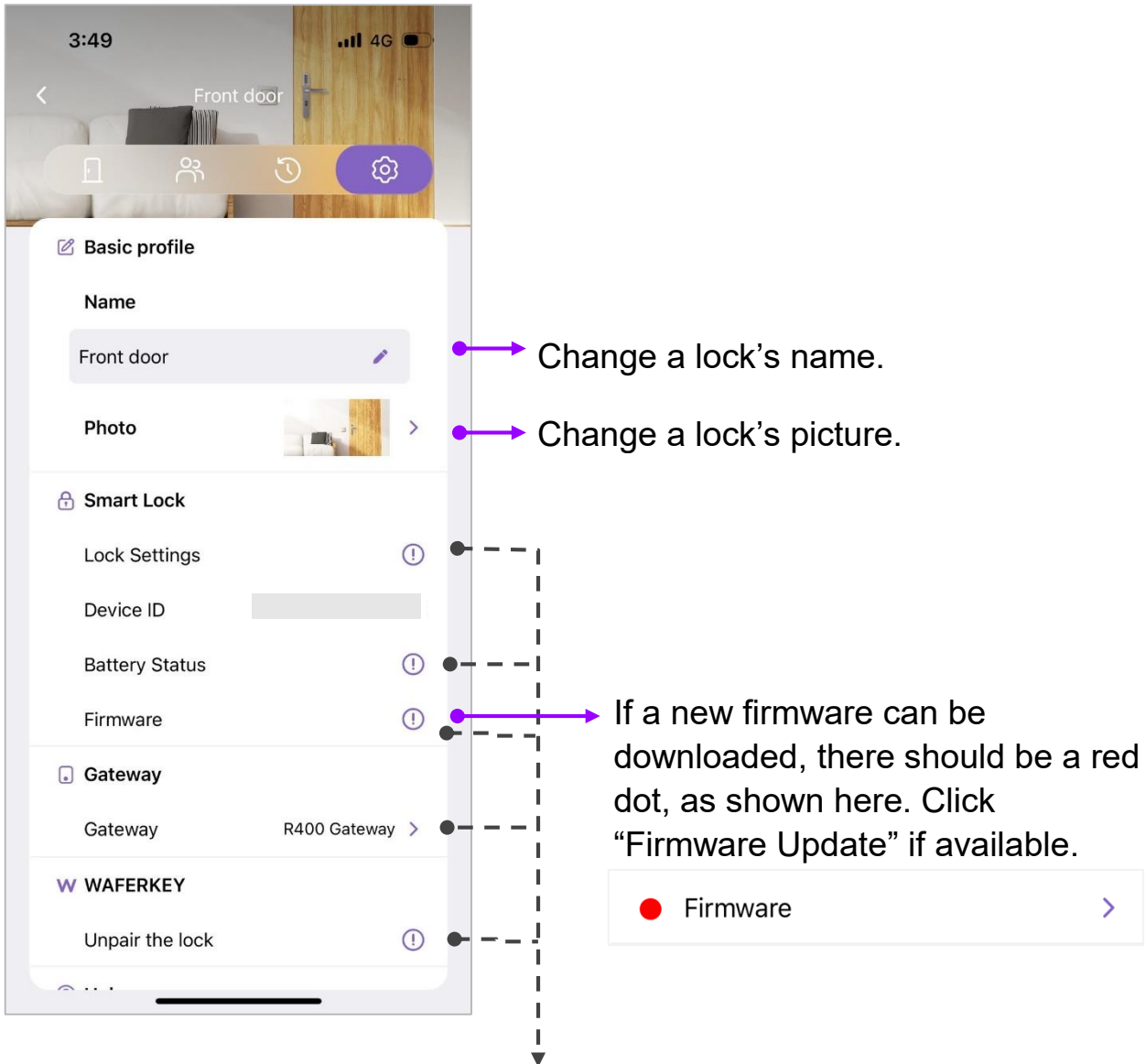

It is available only when connected with Bluetooth.

ⓘ \*It appears only when no devices can be found.

(Demo screenshots were taken from iOS.)

# Gateway Setup Page

Users can adjust various settings related to paired Gateways, allowing users to lock/unlock doors remotely.

- From the list, users can know paired Gateways and locks under.
- Click a Gateway to review its information in details.
- Please note that if there are no locks paired with a Gateway, the Gateway will not appear in the list.

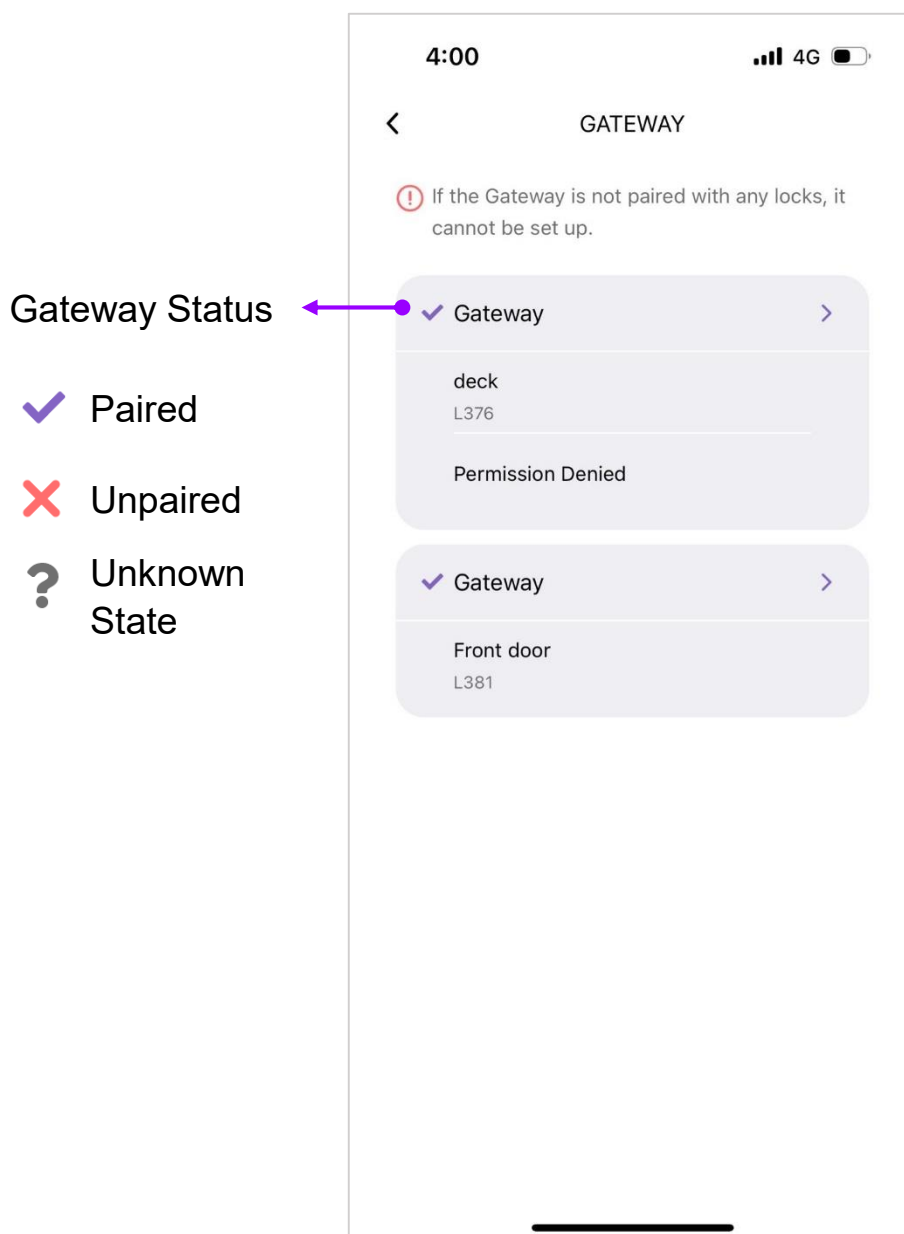

(Demo screenshots were taken from iOS.)

## [A List of Paired Locks under a Gateway]

In this page, users can manage a list of paired locks under a selected Gateway.

- From the list, users can know paired locks under selected Gateway. One Gateway can be paired with up to 5 locks.
- When a lock is paired with Gateway, click “Unpair” button to unpair the lock with Gateway.  
\*Please note that if a lock is not paired with Gateway, users cannot unpair it with Gateway.

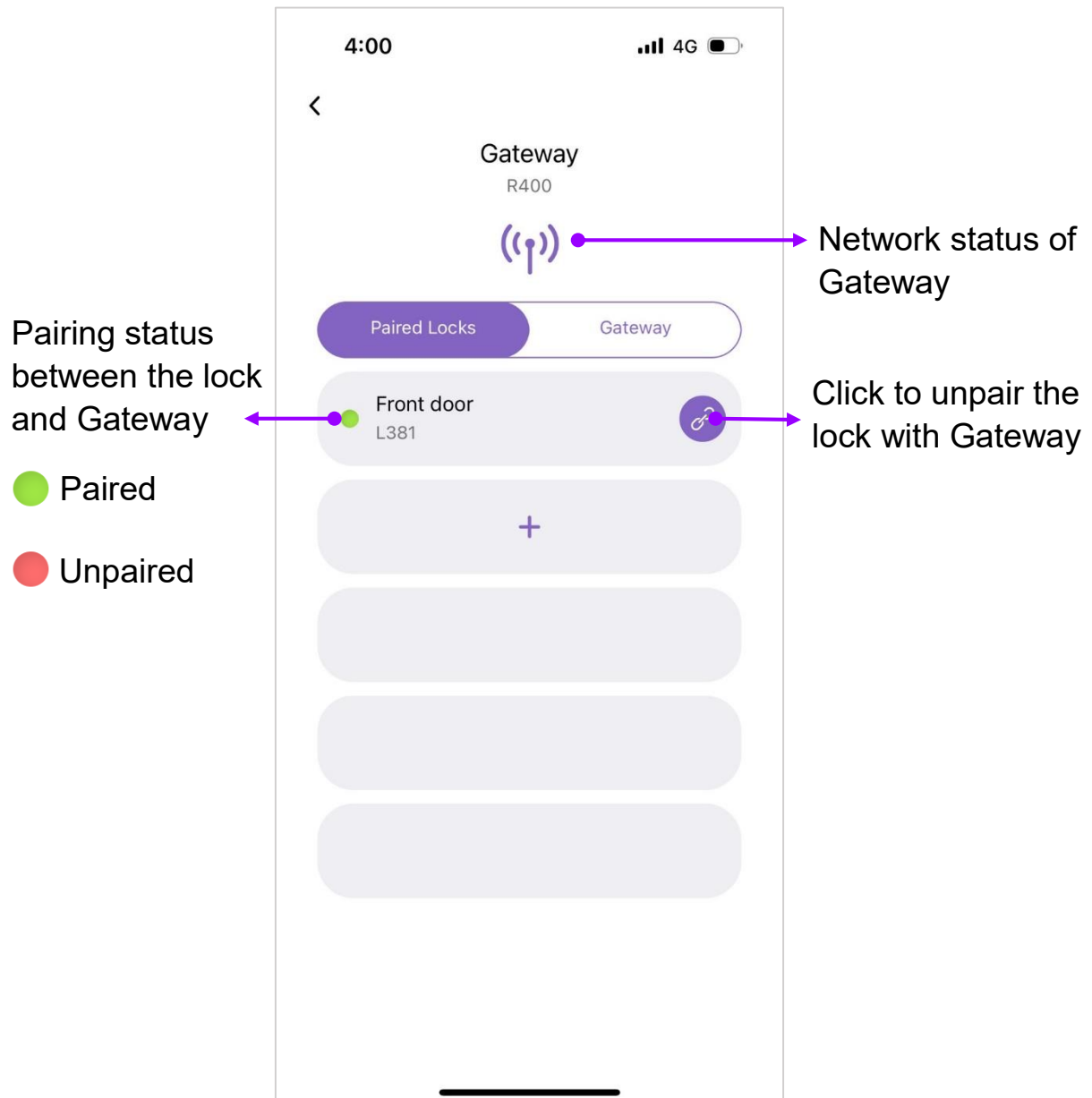

(Demo screenshots were taken from iOS.)

## [Gateway Setup Page]

In this page, users can manage a list of setup functions related to a selected Gateway.

- Users can modify Gateway's name for better recognition and management. The default name is "Gateway".
- Firmware will be updated automatically if a new version is available when the network is connected.
- Only the hardware of Gateway can be reset. Refer to the WAFERKEY App for detailed information.

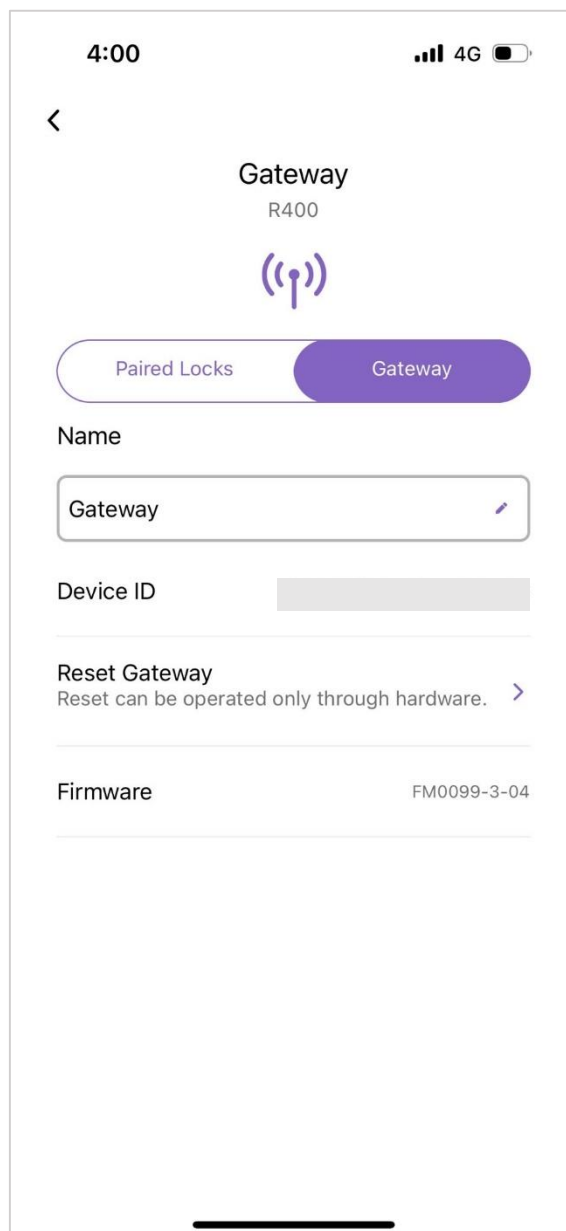

(Demo screenshots were taken from iOS.)

## [Reset Gateway]

Reset will restore the GATEWAY to its initial state. Once executed, it cannot be reverted. Please follow the steps below to start resetting:

1. Prepare a needle or pin for resetting.
2. Insert the needle or pin into the Reset hole; press and hold on for more than 5 seconds. release when the indicator of POWER light starts flashing slowly.
3. Five indicators will start flashing alternately, indicating that the reset process has begun.

The execution will take a while. Please be patient!



(Demo screenshots were taken from iOS.)

# Sidebar

The current version of the App is shown at the bottom page. If you have any feedback or comments, please quote the version number if you contact our customer service team.

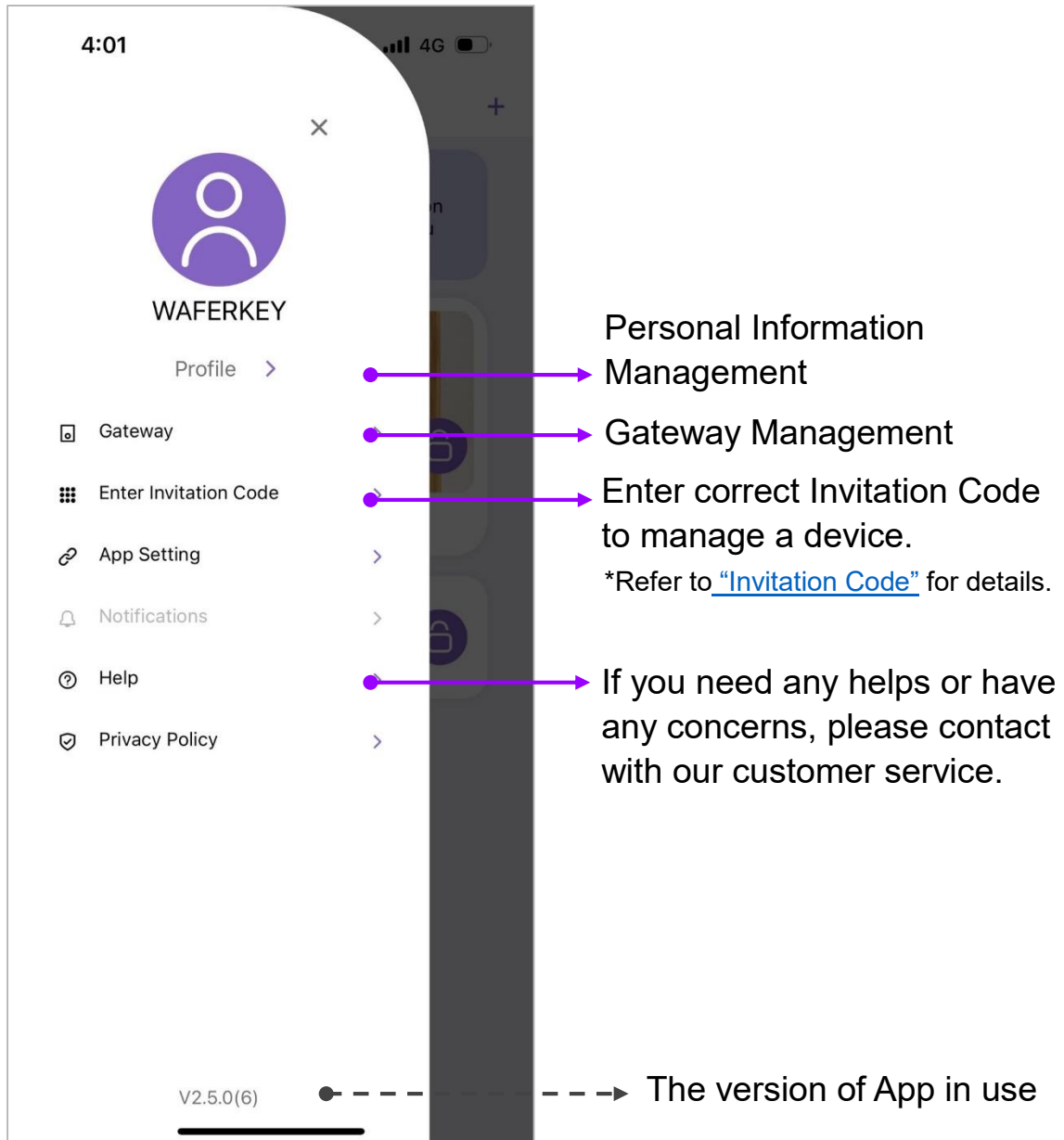

(Demo screenshots were taken from iOS.)

## [ Personal Profile ]

**\*Please take note that once the account has been deleted, it cannot be restored!**

-- Email is used for demo --

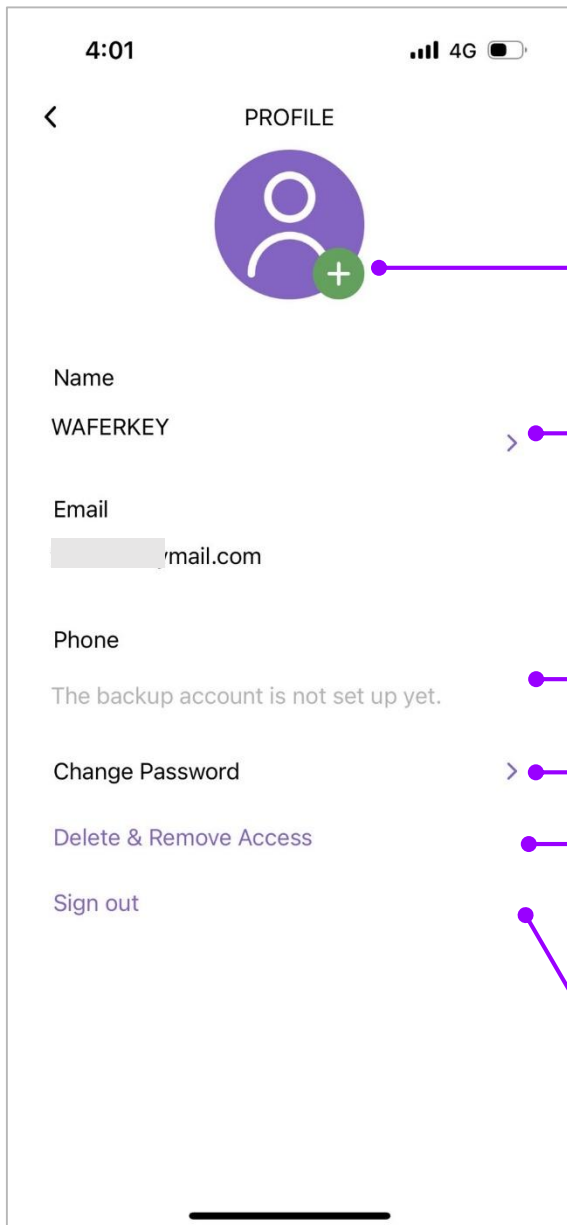

Modify Account Image

Modify Account Name

Add mobile phone (You can also use it to log in the account.)

Modify your password

Delete the account.

**\*Take note that once the account has been deleted, it cannot be restored.**

**\*It can be executed only when the account is not paired with any devices.**

Log out from the account.

(Demo screenshots were taken from iOS.)

## [ App Setting Page ]

In the App Setting page, users can select extra functions, such as vibration feedback or enforced lock method, to ensure the smart access control is safer.

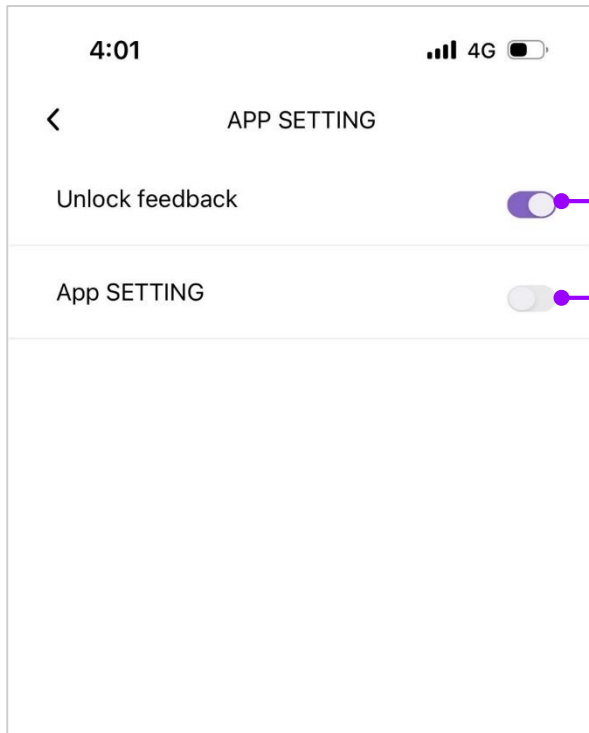

When it is on, users can get a vibration feedback when they unlock the door successfully.

When it is on, users have to unlock the screen lock if they want to activate App

(WAFERKEY does not support Screen Lock-Password.)

\*Please go to the setup page of your phone to arrange the screen lock in advance.

---

## [ Help ]

If you have any concerns or questions, please let us know! Contact us at:

[support.app@waferlock.com](mailto:support.app@waferlock.com)

(Demo screenshots were taken from iOS.)

# Troubleshooting

## ■ What should I do if my lock has been paired with WAFERKEY and I lost my cell phone?

There is no worry about it, for all data is associated with your WAFERKEY account. Just log into your account from a new cell phone and then you will be able to use it successfully.

## ■ What should I do if I forgot my password?

If you log in by a WAFERKEY account,

Click on “Login” and use “Forgot password” to reset your password. Enter your registered email account or phone number and then you will receive a verification message. Click the URL inside to reset a new password for your WAFERKEY account.

If you log in by a third-party account,

Please refer to rules of the third-party account about how to reset your password.

## ■ What should I do if I cannot unlock my door by using WAFERKEY?

At the first step, you have to ensure your lock is in “Nearby” or “Remote” mode.

To check the mode, activate “Lock Control Page” in WAFERKEY and then you will find the lock mode shown and circled in red as below.

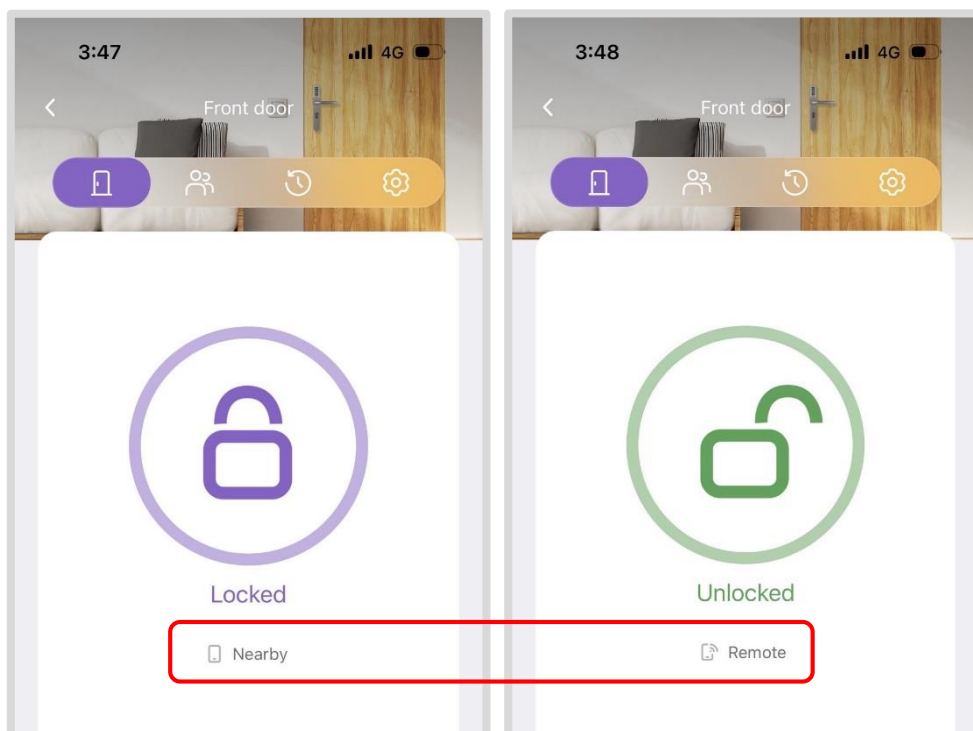

## Lock in Nearby Mode

Please make sure

- ✓ Whether Bluetooth of your cell phone has been turned on. If you are using an Android cell phone, ensure also the function “Location” has been activated.
- ✓ Whether your cell phone is operated under Bluetooth range and close enough to the lock.
- ✓ Whether you can check your lock mode in WAFERKEY App.

If all items listed above have been processed and you still cannot unlock your door, please turn off Bluetooth of your cell phone and then turn it on again to try once more.

## Lock in Remote Mode

Please make sure

- ✓ Whether indicators of Service, WAN and ZigBee on Gateway always remain on, as shown in pic2 below.
- ✓ Whether Gateway and Server are connected properly. (Refer to the section “Add a New Device: Gateway” for how to ensure the connection status. Or, you can check whether indicators of Gateway and Service on Gateway always remain on, as shown in pic2 below.)
- ✓ Whether the lock and Gateway are connected properly. (Refer to the section “Add a New Device: Gateway” for how to ensure the connection status, as shown in pic1 below.)

Indicator in Green (①): Properly connected;  
Indicator in Red: Disconnected

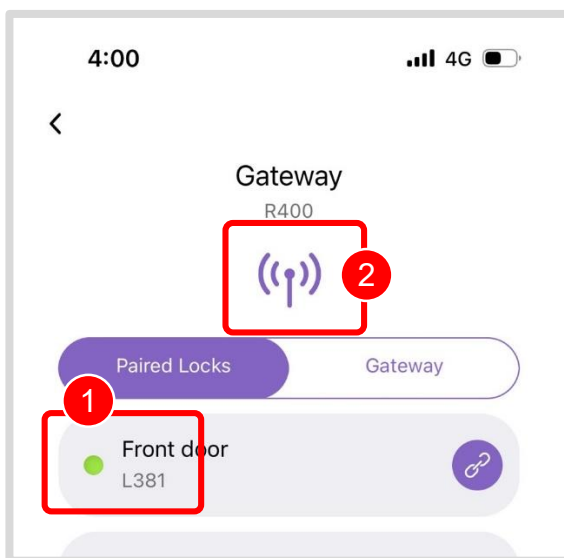

Pic1



pic2

**When Gateway and Server are disconnected,**

Please ensure indicators of Service and WAN on Gateway always remain on, as shown in pic2 above. If they are off, please check at first whether the network provided to Gateway is functioning properly.

**When Lock and Gateway are disconnected and indicator in App is red as shown in pic2 above,**

After using a valid key card to unlock the door, make sure whether the indicator of POWER on Gateway flashes within about 10 seconds. If so, wait 3 minutes and then activate the App again to check if the connection status has returned to normal and is indicated by a green light.

**When the indicator of ZigBee on Gateway does not always remain on,**

Please provide a picture of Gateway and the error message appearing on the screen when unlocking fails. Click “Help” in Sidebar to get in touch with our customer service.

If all items listed above have been processed and you still cannot unlock your door, please click “Help” in Sidebar to get in touch with our customer service.

(Demo screenshots were taken from iOS.)

# Thank you for reading the WAFERKEY User's Guide.

In order to constantly improve our users' experience, we regularly update the WAFERKEY App. Therefore, the WAFERKEY User's Guide may be modified from time to time, based on such adjustments.

Your comments and opinions are important to us. If you have any questions, please contact us at:

[support.app@waferlock.com](mailto:support.app@waferlock.com)